

ASSEMBLY AND LAYING INSTRUCTIONS

SOLAR GREEN ROOF

OPTIGRÜN SOLAR FKD/WRB



SOLAR GREEN ROOF OPTIGRÜN SOLAR FKD/WRB

Before installing and using the solar mounting system, it is necessary for you to have read and understood the assembly and laying instructions. Only in this way is proper operation possible. It also prevents damage to the product that is being used as well as injuries.

Due to the various usages and finishes, the solar mounting system may not be used on the basis of experience with other materials or manufacturers.

Provide these instructions to the personnel responsible for installation and use, and ensure that the designated persons are aware of the information.

If you have any further questions, please contact Optigrün international AG.

Table of contents

1. General information	3
1.1. Brief description	3
1.2. Area of use	3
1.3. Accessories	3
1.4. Special variant	3
1.5. Information for the user	3
2. Transport	4
2.1. Delivery	4
2.2. Unloading	4
2.3. Opening and storage of the package units	4
3. Handling	5
3.1. General information	5
3.2. Handling rules for aluminium structural components	5
4. Installation	7
4.1. General information on installation	7
4.2. Installation	7
4.3. Additional information	15
5. Standards, regulations and safety information	16

Please note:

The information in this document is based on our current knowledge and experience. They do not represent an assurance in a legal sense. During use, the particular conditions of the application are to be taken into account, especially with regard to building physics, building technology and building regulations.

Optigrün international AG

Am Birkenstock 15 - 19
72505 Krauchenwies-Göggingen
Germany

Phone +49 7576 772-0
Fax +49 7576 772-299
Email info@optigruen.de

www.optigruen.com
www.optigruen.at
www.optigruen.nl
www.optigruen.uk

www.optigruen.de
www.optigruen.fr
www.optigruen.pl
www.optigruen.be

1. ALLGEMEINES

1.1 Brief description

Load-supported solar mounting system for roof penetration-free mounting of PV modules or PV module series. Consisting of Base Plate, Mounting Frame and Drainage and Storage Board FKD 25MA or Water Retention Box WRB 8oFMA. Supplied with accessories.

1.2 Area of use

- For the construction of solar green roofs with extensive greening (Optigrün Solar FKD) or for the construction of solar green roofs with extensive greening and retention volume (Optigrün Solar WRB)
- Suitable for orientation of the PV modules in a south and east-west alignment.

1.3 Accessories

- Easy Mounting Rails 36 and 50
- Rail Connector Kit 36 and 50
- Module Clamps
- Wind Bracing
- Spacer Board FKD 25 0.5 m for Optigrün Solar FKD (Optigrün Solar FKD variant)

1.4 Special variant

Solar mounting system Optigrün Solar with pre-fitted Optigrün Adjustable Mounting Rail for free choice of rail spacings.

1.5 Information for the user

Please note!

Only the complete Optigrün System Structure, consisting of Protection and Storage Fleece RMS 500, Drainage and Storage Board FKD 25 or Water Retention Box WRB 8oF, Filter Fleece FIL 150 and Extensive Substrate, forms a tested and statically proven overall system.

Any replacement and any changes to the components or to the intended use lead to the loss of the warranty and liability by Optigrün international AG.

The statements provided in these assembly and laying instructions do not release the planners, the performing company and the user from inspecting and assessing the solar mounting system, the local conditions and other occurrences themselves under the given technical guidelines. Optigrün international AG is to be informed in the event of any doubts concerning the installation and/or use.



2.1 Delivery

Inspect the goods for completeness upon delivery before unloading:

- Is the solar mounting system (Base Plate and Mounting Frame) complete and undamaged?
- Are all accessories complete and undamaged according to the delivery note?
- Is the laying plan supplied?

If you identify any damage, this is to be reported to the carrier and the responsible forwarding agent immediately. You should immediately report the lack of parts or the laying plan to the Optigrün headquarters. The sales department will then organise for the missing parts to be supplied quickly.

2.2 Unloading

As the delivering vehicle does not usually have its own lifting device, the client is to provide a suitable method of unloading the components. This must be a forklift or a crane (with fork or loops) with a lifting capacity of at least 1,000 kg. Delivery by HGV with its own lifting device may be requested in advance. Suitable level, stable storage space is to be provided for the pallets.



CAUTION!

Warning of falling pallets or elements!

Always check pallets are stable.
Never try to support a falling pallet!



WARNING!

Warning of suspended loads!

There is a risk of injury due to suspended loads.
Do not go underneath suspended loads!
Wear a safety helmet!



2.3 Opening and storage of the package units

Before opening the package units, it must be ensured that the structural components lie safely in layers and cannot fall off. When opening, it must be ensured that the elements are not damaged by tools or similar.

The supplied plastic drainage and retention elements are stored flat in a cool, dry place protected from UV. Due to the expansion behaviour and low compressive strength of plastics in the event of high temperatures, heating of the Drainage and Storage Boards FKD 25MA and Water Retention Boxes WRB 80FMA above 40°C must be avoided.

3. HANDLING

3.1 General information



PLEASE BE SURE TO NOTE THE FOLLOWING INFORMATION

Non-observance can lead to injuries.

When handling the components on a construction site, it must be ensured that suitable protective clothing is worn (safety gloves, safety shoes, etc.). Due to the manufacturing procedure, edges can display ridges. These are not defects.



CAUTION!

Warning of danger of cuts!

There is the risk of injury as edges can display ridges as a result of manufacture.



CAUTION!

Warning of injuries!

Generally take care when handling the components due to the risk of injury.

There is the risk that fingers or other body parts may be crushed or otherwise injured.



Wear protective gloves!

Use the products according to these assembly and laying instructions.

Ensure that the products and the materials used meet the requirements (e.g. load-bearing capacity of the base).

Do not use any damaged, old or previously used products or materials.

Please be aware of any specific conditions or regulations in force on the individual site.

In situations that are not covered in these instructions and the valid standards and regulations, a written agreement with Optigrün international AG is required.

3.2 Handling rules for aluminium structural components

- Material compatibility with jointly processed materials is to be verified with regard to possible contact corrosion.
- In the event of contact with (salty) sea air, seawater, (dissolved) grit, chemicals and other special environmental influences, the use of the solar mounting system is to be checked.
- It should be ensured that the material of the solar mounting system and its associated structural components are not exposed to any aggressive leaching from other materials.
- Abrasive and/or aggressive detergents may not be used.
- To fertilise the substrate, use the slow-release fertiliser Optigrün Opticote.
The fertiliser may be applied to the substrate surface at a maximum of 35 g/m².
The use of liquid fertilisers is prohibited.

4. Installation

4.1 General information on installation

An approved installation plan from Optigrün international AG must be available for the installation of the solar mounting system. The dimensions listed in this plan for edge and row spacing, the specified orientation and the necessary minimum superimposed loads must be observed.

Additional installation materials may be required (lightning protection, cable ducts, etc.) in addition to the structural components mentioned and supplied as accessories. These requirements must be coordinated in advance with the solar installer and, if necessary, the lightning protection engineer and must be kept ready in good time for assembly.

It must be ensured that the available waterproofing is root proof according to the FLL Guidelines. Moreover, only PV modules that have the following valid certificates may be used:

IEC 61215 / IEC 61730 (Further standards, regulations and safety information cf. p. 16.)

Tools and materials required for assembly:



Cordless screwdriver



Hexagon socket bit size: 6 mm



Scissors



Bit for Phillips head screws



Spirit level



String



Angle grinder



Tape measure



Torque wrench



Hand soldering iron



Compass

4.2. Work steps:

Work step 1: Prepare the roof area

Ensure roof area is in a clean and tidy condition and check that it is level.

Optigrün Protection and Storage Fleece RMS 500 must be laid first to protect the waterproofing. It should be ensured that the protection fleeces overlaps by at least 100 mm and are sufficiently high at the structural components that the waterproofing is protected. If unevenness is ascertained after rolling out the protection fleece (e.g. the formation of hollows > 10 mm deep and > 4 m² area in places), compensatory measures must be taken so that the PV modules can later be correctly mounted.

To do this, use a fine-grained drainage material (e.g. Perl 2/10 expanded shale, expanded clay or lava) on the Optigrün Protection and Storage Fleece RMS 500 to extensively level out the areas of unevenness. Ideally spread the loosely applied material level with the surrounding area using an aligning pole.

4. Installation

Work step 2: Installation and positioning Base Plate Optigrün Solar

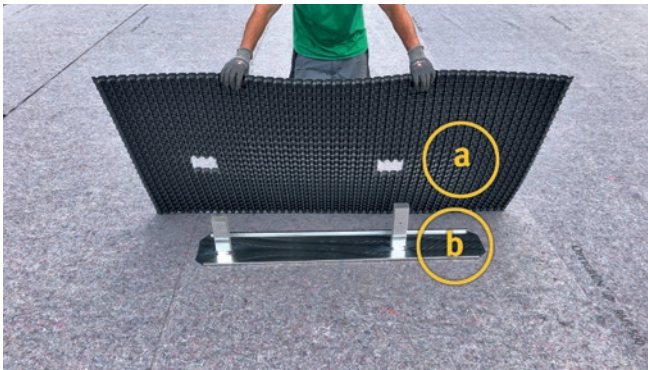

Figure 1: Installation FKD on Base Plate.

Place the Drainage and Storage Board FKD 25MA or Water Retention Box WRB 8oFMA (cf. page 9) above the Base Plate as shown in **Fig. 1**.

Please note! Make sure that the longer side of the FKD/WRB (a) is above the longer side of the Base Plate (b). This has an influence on the stability of the overall superstructure!

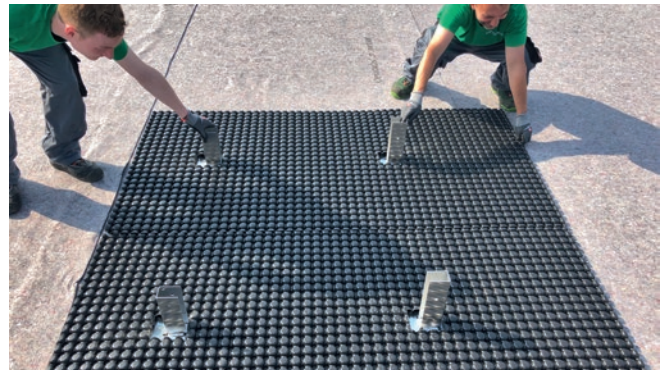

Figure 2: Formation of rows according to the installation plan.

Distribute the first rows of Base Plates with FKD 25MA/WRB 8oFMA according to the manufacturer's installation plan.

For better orientation, it is recommended to first place the rows along the transverse and longitudinal sides of the roof to form a right angle, see also **Fig. 4**. The edge spacings are to be observed. It is important that the exact orientation towards specified direction is verified using a compass. Align the Base Plates so that the support on the Base Plate without a notch (a), as shown in **Fig. 4**, points towards the specified direction.



Figure 3: Installation of additional FKD 25 without Base Plate to create the spacing according to the installation plan.

To achieve the correct spacing between the Base Plates, Spacer Boards FKD 25 0.5 m or individual FKD 25/WRB 8oF without Base Plates may have to be laid between the FKD 25MA/WRB 8oFMA **Fig. 3**.

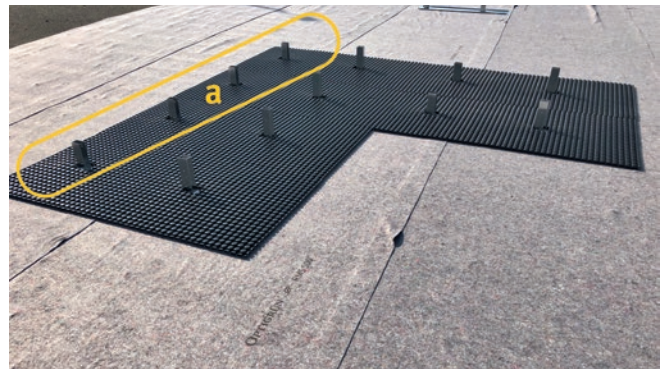

Figure 4: Installation at a right angle.

4. Installation

Special characteristics when using the Optigrün Water Retention Box WRB 80FMA:



Figure 5: Laying out the Base Plate with WRB 80FMA.

Place the WRB 80FMA unfolded with the open side facing upwards over the Base Plate.



Figure 6: First WRB 80FMA placed unfolded on Base Plate.

As in **Fig. 6**, the open side of the WRB 80FMA must face upwards.

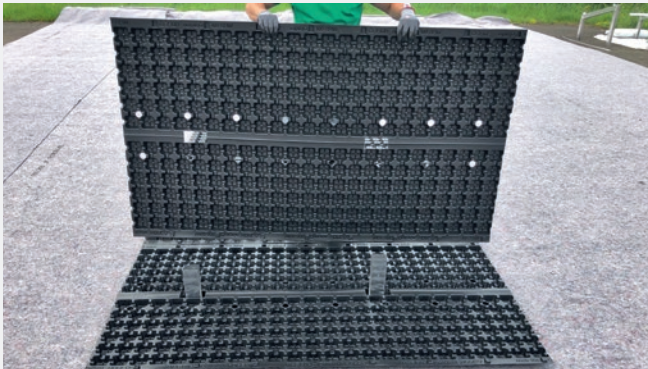

Figure 7: Placing of the second WRB 80FMA on the Base Plate.

Then place another unfolded WRB 80FMA with the open side facing downwards on the first WRB 80FMA **Fig. 7**.



Figure 8: WRB 80FMA 8 cm with Base Plate.

This creates another retention element with a height of 80 mm **Fig. 8**.



Figure 9: Close the click system.

Finally, close the click system on the long sides of the WRB 80FMA again **Fig. 9**.

The rest of the instructions are valid for superstructures with both types of drainage elements (FKD 25/WRB 80F).

4. Installation

Work step 3: Laying of Filter Fleece



Figure 10: Rolling out the Filter Fleece.



Figure 11: Smooth out the fleece.

Roll out the Filter Fleece as close as possible to the middle of a row of installed FKDs/WRBs **Fig. 10** and smooth out as much as possible **Fig. 11**.



Figure 12: Piercing



Figure 13: Cutting

Pierce the centre of the outer edge of the U-shaped supports with scissors **Fig. 12** and make a cut approximately the same length as the support width **Fig. 13**.



Figure 14



Figure 15

Pull the cut fleece down over the support **Fig. 14 and Fig. 15**.

4. Installation



Figure 16: Lay second row of fleece.

When rolling out and laying the Filter Fleece for the following row, make sure that the pieces of fleece overlap by at least 10 cm **Fig. 16**.



Figure 17: Bond rows of fleece with hand soldering iron

Cover all FKDs/WRBs with Filter Fleece as shown.

It is recommended to bond the overlap with building adhesive or with a hand soldering iron. The hand soldering iron should only be used with extreme caution! When using, make sure that the fleece is not being damaged.

Work step 4: Installation of the Mounting Frame



Figure 18: Align the Mounting Frame above the Base Plate.

Please note!

The longer side of the Mounting Frame is marked with a notch.

It must be inserted into the support on the Base Plate, which is as well marked with a notch **Fig. 18**.

This has an influence on the stability of the overall superstructure!



Figure 19: Installation of the Mounting Frame on the Base Plate.

Insert the Mounting Frame as far as it will go into the support on the Base Plate **Fig. 19**.

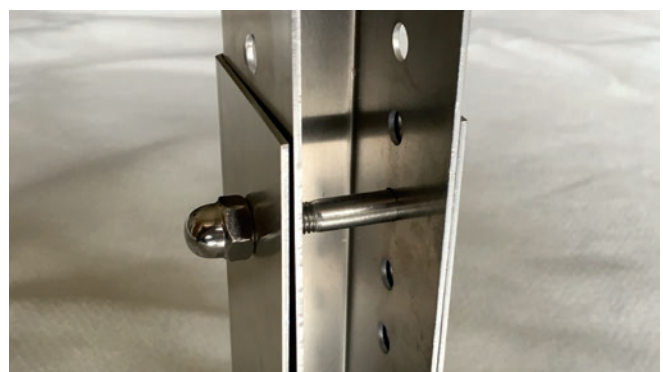

Figure 20: Fastening of the Mounting Frame with shaft screw and cap nut.

Secure the Mounting Frame on both supports with the supplied shaft screws and cap nuts **Fig. 20**.

4. Installation

Work step 5: Fastening of the Easy Mounting Rails



Figure 21: Alignment of the row using string

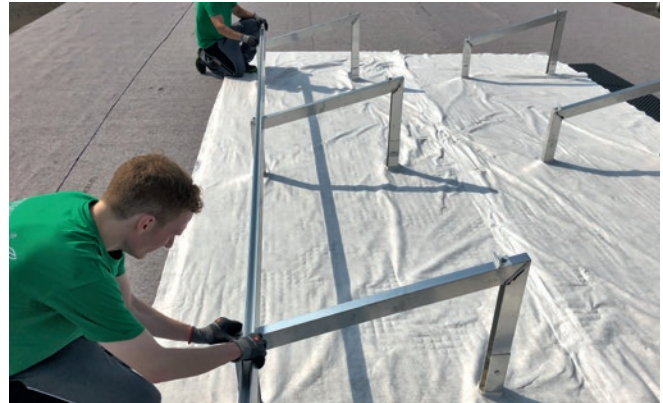

Figure 22: Mounting the first Easy Mounting Rail.

Before installing the Easy Mounting Rails, check the orientation of the solar mounting system based on the installation plan and correct the position if necessary.

The solar mounting system can be easily shifted lengthwise for fine adjustment without moving the FKDs/WRBs. Alignment can be performed, for example, with a string *Fig. 21*.

Latch the Easy Mounting Rails into the Rail Fixings on the Mounting Frame *Figs. 22 and 23* and tighten the cylinder head screw on the Rail Fixing *Fig. 24*.

Loosen the threaded joints of the Rail Fixings if necessary before latching.

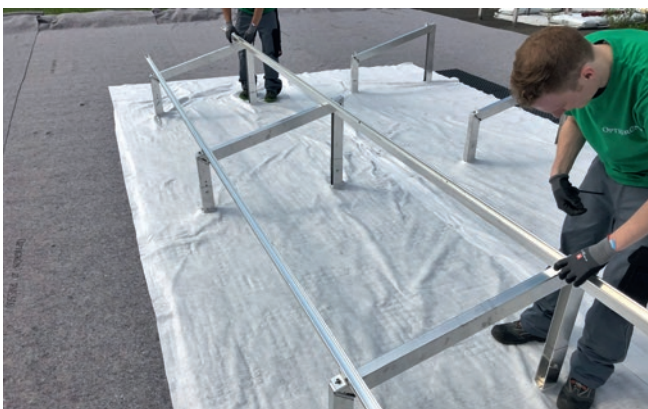

Figure 23: Mounting the second Easy Mounting Rail.



Figure 24: Tighten Rail Fixings.

If height differences are ascertained during the assembly of the Easy Mounting Rails, the height of the Mounting Frames can also be adjusted.

The Mounting Frames can be raised by fixing both feet of the Mounting Frame in a higher hole of the support on the Base Plate. The Mounting Frames can be lowered by cutting the feet of the Mounting Frame evenly with an angle grinder.

To form a row of rails, screw together the adjacent Easy Mounting Rails without spacing using the supplied Rail Connector Kit *Fig. 25*.

Please note!

The Easy Mounting Rails should only be assembled in a set of 4 due to thermal expansion.

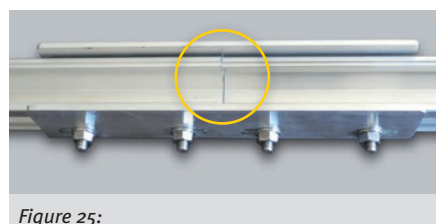

Figure 25:

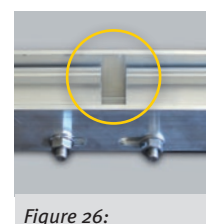

Figure 26:

Therefore a distance of 2 cm in every fifth connector is to be left between the Easy Mounting Rails *Fig. 26*. This ensures that the maximum length of the Easy Mounting Rails which are directly connected is 21.5 m.

4. Installation

Work step 6: Fastening of the Wind Bracing



Figure 27: Removing the protective film from the wind bracing.

Remove any protective film from the wind bracing (flat aluminium strip) **Fig. 27** .

Create one wind brace per row with two flat strips.



Figure 29: Position of drilled holes

Use the drill holes provided for this purpose (a and b).



Figure 31: Wind bracing.

Finished wind bracing **Fig. 31** .



Figure 28: Fastening of the metal strip.

To do this, connect two Solar Mounting Frames in a row using the flat strips and the supplied stainless steel drilling screws, making a cross shape **Figs. 28 and 29** .



Figure 30: Cutting off the overhang from the wind bracing.



Angle grinder safety notice

Warning of injuries!

- Wear safety goggles and hearing and respiratory protection.
- Wear close-fitting protective clothing.
- Remove fire-sensitive materials.
- Before using the angle grinder, read the instruction manual.

Cut off the overhanging parts of the wind bracing with the help of an angle grinder **Fig. 30** .



Figure 32: Additional drill hole on the long side of the Mounting Frame.

On the long side of the Mounting Frame, there is an additional drill hole on the outside. This can be used e.g. for installing lightning protection devices or cable ducts **Fig. 32** .

4. Installation

Work step 7: Ballasting of the solar mounting system



Figure 33: Blowing of the substrate.

Apply Extensive Substrate as ballast material to the superstructure. To blow the substrate, it is recommended to use a cylindrical blower [Fig. 33](#), which makes it easier to fill the gaps.

The minimum required superimposed load weight is to be found in the planning.

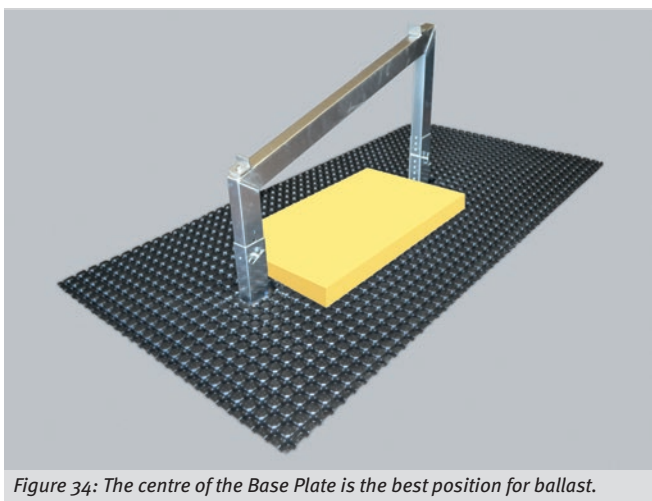

Figure 34: The centre of the Base Plate is the best position for ballast.

In addition to the substrate, an additional ballast, usually in the form of stones, may also be necessary (see the manufacturer's installation plan). If necessary, apply additional ballast on the FKD 25MA/ WRB 80FMA in the centre of the Base Plate [Fig. 34](#). If stones are used, they must be placed on the substrate, not on the drainage mat.

When applying the substrate, check the alignment of the Easy Mounting Rails and, if necessary, realign the solar mounting system, as by curving the Easy Mounting Rails the PV modules would not be aligned either.

The height of the loose material for each individual row is to be documented sufficiently. Only in this way can a warranty claim be made.

The height of the screw in the supports on the Base Plate can be used as a reference point for the material height (see [Fig. 19](#)).

The height of the screw is:

- 145 mm above the Drainage and Storage Board FKD 25
- 80 mm above the Water Retention Box WRB 80F

Only sedum cuttings are usually used on the fully installed substrate as high-growing herbs and grasses can lead to shading of the PV modules and thus to performance losses.

Work step 8: Fastening of the PV modules

Fix the PV modules to the Easy Mounting Rails vertically (portrait) or horizontally (landscape) using Module Clamps.

Apply the first module at one end of a row. Align the module in the middle and at a right angle corresponding to the orientation from the planning documents (landscape or portrait) on the Easy Mounting Rails. Secure the module at the end of the Easy Mounting Rails using two Module End Clamps and tighten it with 14 Nm. On the other side of the module, attach two Module Middle Clamps and apply and align the next module. Fasten the modules with the Module Middle Clamps and tighten the Module Middle Clamps with 14 Nm torque. Apply and fasten the whole row, based on the planning documents. The last module must be fixed once again with two Module End Clamps on the outer side.

Any overhang of the Easy Mounting Rails can be shortened with an angle grinder after fastening the PV modules.

The following points must be noted during assembly:

- When mounting, the manufacturer's specified clamping ranges must be observed.
- The torque of the clamp screws must be 14 Nm.
A suitable torque wrench or cordless screwdriver with a torque limit is to be used for this.

Please note!

Lower torques can lead to the failure of the system. Higher torques can damage the module frame and PV modules.

- Contact corrosion between the PV module frame and substructure is to be prevented when using different materials.
- Do not drill, nail or weld the module frame.
- Only use corrosion-free screws for assembly.
- Install PV modules only with the socket in the direction of the long side of the Mounting Frame.

Work step 9: Electrical connections

(exclusively established by an electrician/solar installer)

Observe the instructions of the PV module manufacturer for the electrical connection of the PV modules.

4.3 Additional information

Setting up individual PV module pairs and setting up the modules in a manner that deviates from the design by Optigrün international AG is only permissible following coordination and written approval from the manufacturer of the solar mounting system (Optigrün international AG).

Information on statics

In the event of an order, the solar mounting system is installed according to the superimposed load and static calculations of Optigrün international AG. The customer is responsible for the static approval of the building area to be covered.

5. Standards, regulations and safety information

When assembling the solar mounting system, the accepted rules of technology and the accident prevention regulations must fundamentally be observed.

This includes, in particular:

- BGV A1 General regulations
- BGV A2 Electrical facilities and working materials
- BGV C22 Construction works
- BGV D36 Ladders and steps

Furthermore, local/regional regulations and all regulations under public law, DIN standards, TAB (technical connection conditions), accident prevention regulations, the guidelines of the Verband der Sachversicherer (VdS), the technical regulations of the German roofing trade and general guidelines (e.g. timber wood constructions, roof covering and roof sealing work) are to be observed when designing, installing, operating and maintaining the PV system.

This includes, in particular:

- DIN /VDE 0100 (Installing high-voltage systems with nominal voltages of up to 1000V)
- DIN /VDE 0100 Part 712 (Installing (low-voltage) solar photovoltaics (PV) power supply systems)
- DIN /VDE 0298 (Application of cables and cords in power installations)
- VDI 6012 (Local energy systems in buildings - photovoltaics)
- DIN /VDE 0126 (Solar plants for domestic use)
- DIN /VDE 0185 Part 1 to 4 (Protection against lightning)
- DIN EN 1991-1 1-4/NA (Wind actions)
- DIN 1055 Part 5 (Snow loads and ice loads)
- DIN 18338 Roofing work
- DIN 18451 Scaffolding works
- DIN 1052 Part 1 and Part 2 Dimensioning of the substructure (timber wood constructions)
- TAB (technical connection conditions for energy supply companies)
- VDEW directives (directive on the connection and parallel operation of power generating systems to the low-voltage network)

Lightning and overvoltage protection:

The installation of lightning and surge protection is the responsibility of the solar installer or lightning protection engineer.

Lightning and overvoltage protection is to be provided in accordance with the current requirements of the standards DIN/VDE 0185 Part 1 to 4, DIN/VDE 0100 Part 712 and VdS 2010. Please find detailed recommendations and information in the directives and standards listed. Sufficient lightning protection is to be recommended, particularly in exposed locations. Integration into existing lightning protection facilities must take place while abiding by the valid country-specific standards and regulations.

Please note the instructions of the manufacturer of the PV modules!

Cable laying:

When assembling the frame, certain points of cable routing and cable laying should be taken into account.

- To avoid surge voltage coupling due to lightning, the conductor loop that is created should be kept as small as possible.
- Cable laying must safely ensure that snow and ice slide off later on.
- The cables must be laid where possible with UV and weather protection. It is recommended that the cables are laid in suitable cable conduits. It should be ensured that no water can accumulate as a result of this.

Optigrün international AG

Am Birkenstock 15 - 19
72505 Krauchenwies-Göggingen
Germany

Phone +49 7576 772-0
Fax +49 7576 772-299
Email info@optigruen.de

www.optigruen.com
www.optigruen.at
www.optigruen.nl
www.optigruen.uk

www.optigruen.de
www.optigruen.fr
www.optigruen.pl
www.optigruen.be